

# PARAGON GB3221

## Preconfigured DSP System for Hearing Aids

### Description

The Paragon GB3221 hybrid is a programmable DSP system based on a multi-channel compression circuit. This hybrid is designed for low impedance receivers. It can be used as a platform for a wide range of hearing aid applications. It also offers a separate supply line to the A/D and H-Bridge circuits. The reflowable thinSTAX<sup>®</sup> packaging enables easy integration into BTE applications. This versatile DSP hybrid is capable of multiple configurations and has a wide range of functions.

The Paragon GB3221 hybrid contains the GC5057 controller featuring Power On Reset (POR) behavior.

The Paragon GB3221 hybrid code programmed into the GC5051 and the GC5057 controller chip is "7".

### Features

- High Power Applications
- Highly Configurable, Versatile DSP Platform
- High Fidelity, Multi-channel AGC Signal Processing
- 93 dB Input Dynamic Range with HRX™ Headroom Extension
- Fully Programmable via Serial Data Interface
- High Performance Data Converters – Dual, Over-sampled A/Ds; Over-sampled D/A with Efficient Switched-mode Output Power Amp
- High-fidelity Audio Quality
- Drives Zero-bias 2-terminal Receivers
- Multiple Communication Rates up to 85.3 kb/s
- Multi-memory
- Internal/External Volume Control
- Volume Control Taper determined by External VC
- Two Memory Select Pads
- Tri-state Memory Select Operation
- Audible Memory Change Indicator
- Also Available as E1 RoHS Compliant Hybrid

### thinSTAX Packaging

- Hybrid Typical Dimensions:  
0.227 x 0.125 x 0.060 in  
(5.76 x 3.18 x 1.52 mm)



ON Semiconductor®

<http://onsemi.com>

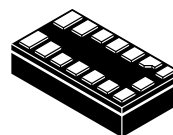

15 PAD  
PARAGON  
CASE TBD

### PAD CONNECTION

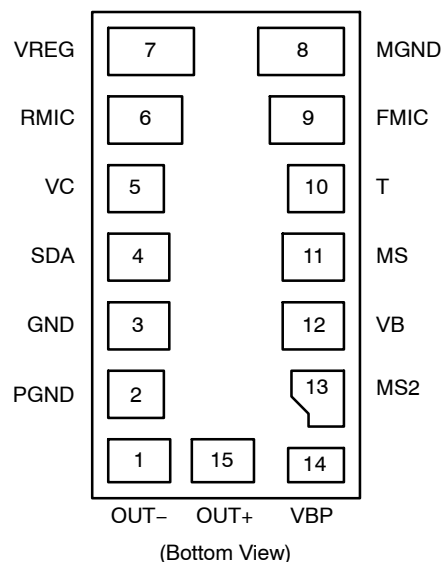

### MARKING DIAGRAM

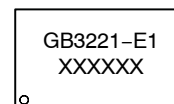

GB3221 = Specific Device Code  
E1 = RoHS Compliant Hybrid  
XXXXXX = Work Order Number

### ORDERING INFORMATION

Device	Shipping†
GB3221-E1	25 Units / Bubble Pack

†For information on tape and reel specifications, including part orientation and tape sizes, please refer to our Tape and Reel Packaging Specification Brochure, BRD8011/D.

# PARAGON GB3221

## BLOCK DIAGRAM

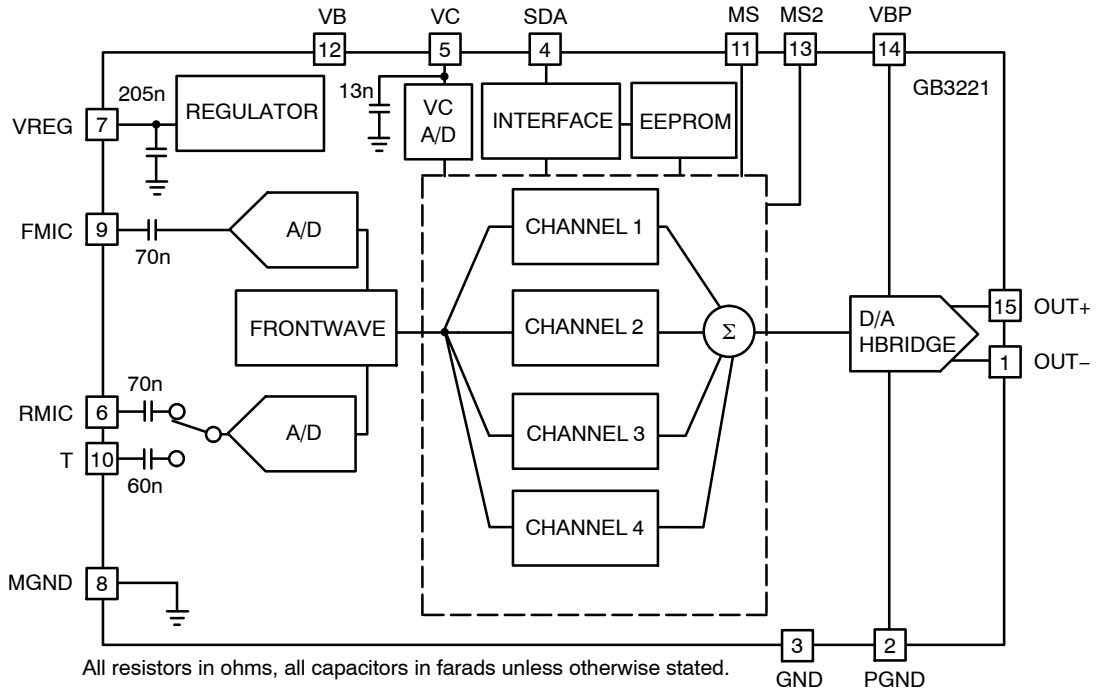

Figure 1. Paragon GB3221 Block Diagram

Table 1. ABSOLUTE MAXIMUM RATINGS

Parameter	Value	Units
Operating Temperature Range	-10 to +40	°C
Storage Temperature Range	-20 to +70	°C
Absolute Maximum Power Dissipation	25	mW
Maximum Operating Supply Voltage	1.5	VDC
Absolute Maximum Supply Voltage	2	VDC

Stresses exceeding those listed in the Maximum Ratings table may damage the device. If any of these limits are exceeded, device functionality should not be assumed, damage may occur and reliability may be affected.

**WARNING:** Electrostatic Sensitive Device – Do not open packages or handle except at a static-free workstation.

**WARNING:** Moisture Sensitive Device – Non-RoHS Compliant – Level 3 MSL; RoHS Compliant – Level 4 MSL. Do not open packages except under controlled conditions.

# PARAGON GB3221

**Table 2. ELECTRICAL CHARACTERISTICS** (Conditions:  $V_B = 1.3\text{ V}$ ; Temperature =  $25^\circ\text{C}$ )

Parameter	Symbol	Conditions	Min	Typ	Max	Units
Hybrid Current	$I_{AMP}$	See current consumption section	–	700	–	$\mu\text{A}$
Minimum Operating Supply Voltage	$V_{BOFF}$	Ramp down	0.94	1.0	1.05	V
Supply Voltage Turn On Threshold	$V_{BON}$	Ramp up	1.06	1.10	1.16	V
Supply Voltage Hysteresis	–	–	90	100	110	mV
Supply Voltage during Communication	$V_{BC}$	During Communication	1.19	1.35	1.5	V
Hybrid Current during Communication	$I_P$	Programming (<5 ms)	–	3.7	–	mA
EEPROM Burn Cycles	–	(Note 2)	100 k	–	–	cycles
Low Frequency System Bandwidth	–	–	100	140	225	Hz
High Frequency System Bandwidth	–	–	15.2	16	16.8	kHz
Total Maximum System Gain	$A_V$	$V_{IN} = -95\text{ dBV}$ at 3 kHz; squelch disabled (Note 1)	81	83	85	dB
Converter Gain	$A_{CONV}$	A/D + D/A gain	27	29	31	dB
Total Harmonic Distortion	THD	$V_{IN} = -40\text{ dBV}$	–	0.05	1	%
THD at Maximum Input	$THD_M$	$V_{IN} = -15\text{ dBV}$ , HRX – ON	–	1.5	3	%
Clock Frequency	$f_{clk}$	–	1.945	2.048	2.151	MHz

## REGULATOR

Regulator Voltage	$V_{REG}$	–	0.90	0.95	1.00	V
Regulator Supply Rejection	$PSRR_{REG}$	–	–	50	–	dB

## INPUT

Input Referred Noise	IRN	Bandwidth 100 Hz – 8 kHz	–	–108	–106	dBV
Input Impedance	$Z_{IN}$	–	11.2	16	22	$k\Omega$
Anti-alias Filter Rejection (input referred)	–	$f = f_{clk} - 8\text{ kHz}$ , $V_{IN} = -40\text{ dBV}$	–	80	–	dB
Maximum Input Level	–	–	–	–15	–	dBV
Input Dynamic Range	–	HRX – ON, Bandwidth 100 Hz – 8 kHz	–	93	–	dB
Audio Sample Rate	–	–	30.4	32	33.6	kHz

## OUTPUT

Maximum RMS Output Voltage	–	0 dBFS $f = 1\text{ kHz}$	–3	–1	1	dBV
D/A Dynamic Range	–	Bandwidth 100 Hz – 8 kHz	80	–	–	dB
Output Impedance	$Z_{OUT}$	(Note 2)	–	–	20	$\Omega$

## VOLUME CONTROL

Volume Control Resistance	$R_{VC}$	–	160	200	240	$k\Omega$
Volume Control Range	$\Delta A$	–	47.5	48	48.5	dB

## MS INPUT

Low State	Lo	–	0	–	$V_{REG}/3$	V
Open State	Z	–	$V_{REG}/3$	–	$2V_{REG}/3$	V
High State	Hi	–	$2V_{REG}/3$	–	$V_B$	V

Product parametric performance is indicated in the Electrical Characteristics for the listed test conditions, unless otherwise noted. Product performance may not be indicated by the Electrical Characteristics if operated under different conditions.

- Total System Gain consists of: Wideband System Gain + High and Low Independent Channel Gains + Converter Gain.  
Total System Gain is calibrated during Cal/Config process.
- Sample tested.

# PARAGON GB3221

**Table 2. ELECTRICAL CHARACTERISTICS** (Conditions:  $V_B = 1.3\text{ V}$ ; Temperature =  $25^\circ\text{C}$ )

Parameter	Symbol	Conditions	Min	Typ	Max	Units
<b>MS2 INPUT</b>						
Pull Down Resistance	-	-	-	1	-	$\text{M}\Omega$
Logic 1 Voltage	-	-	$V_{\text{REG}}$	-	$V_B$	V
Rising Edge Threshold	-	-	0.5	0.69	0.9	V
Falling Edge Threshold	-	-	0.25	0.45	0.5	V
Hysteresis	-	-	0.1	0.24	0.4	V
<b>SDA INPUT</b>						
Logic 0 Voltage	-	(Note 2)	0	-	0.3	V
Logic 1 Voltage	-	(Note 2)	1	-	1.3	V
<b>SDA OUTPUT</b>						
Standby Pull Up Current	-	-	1.4	2	2.6	$\mu\text{A}$
Sync Pull Up Current	-	-	450	500	550	$\mu\text{A}$
Logic 0 Current (Pull Down)	-	-	225	250	275	$\mu\text{A}$
Logic 1 Current (Pull Up)	-	-	225	250	275	$\mu\text{A}$
Synchronization Time (Synchronization Pulse Width)	$T_{\text{SYNC}}$	Baud = 0	237	250	263	$\mu\text{s}$
		Baud = 1	118	125	132	
		Baud = 2	59	62.5	66	
		Baud = 3	29.76	31.25	32.81	
		Baud = 4	14.88	15.63	16.41	
		Baud = 5	7.44	7.81	8.20	
		Baud = 6	3.72	3.91	4.10	
		Baud = 7	1.86	1.95	2.05	

Product parametric performance is indicated in the Electrical Characteristics for the listed test conditions, unless otherwise noted. Product performance may not be indicated by the Electrical Characteristics if operated under different conditions.

- Total System Gain consists of: Wideband System Gain + High and Low Independent Channel Gains + Converter Gain.  
Total System Gain is calibrated during Cal/Config process.
- Sample tested.

## Support Software

Paragon GA3221 is fully supported by ON Semiconductor's software tools available at ARKonline® website <http://ark.onsemi.com/>.

# PARAGON GB3221

## TYPICAL APPLICATIONS

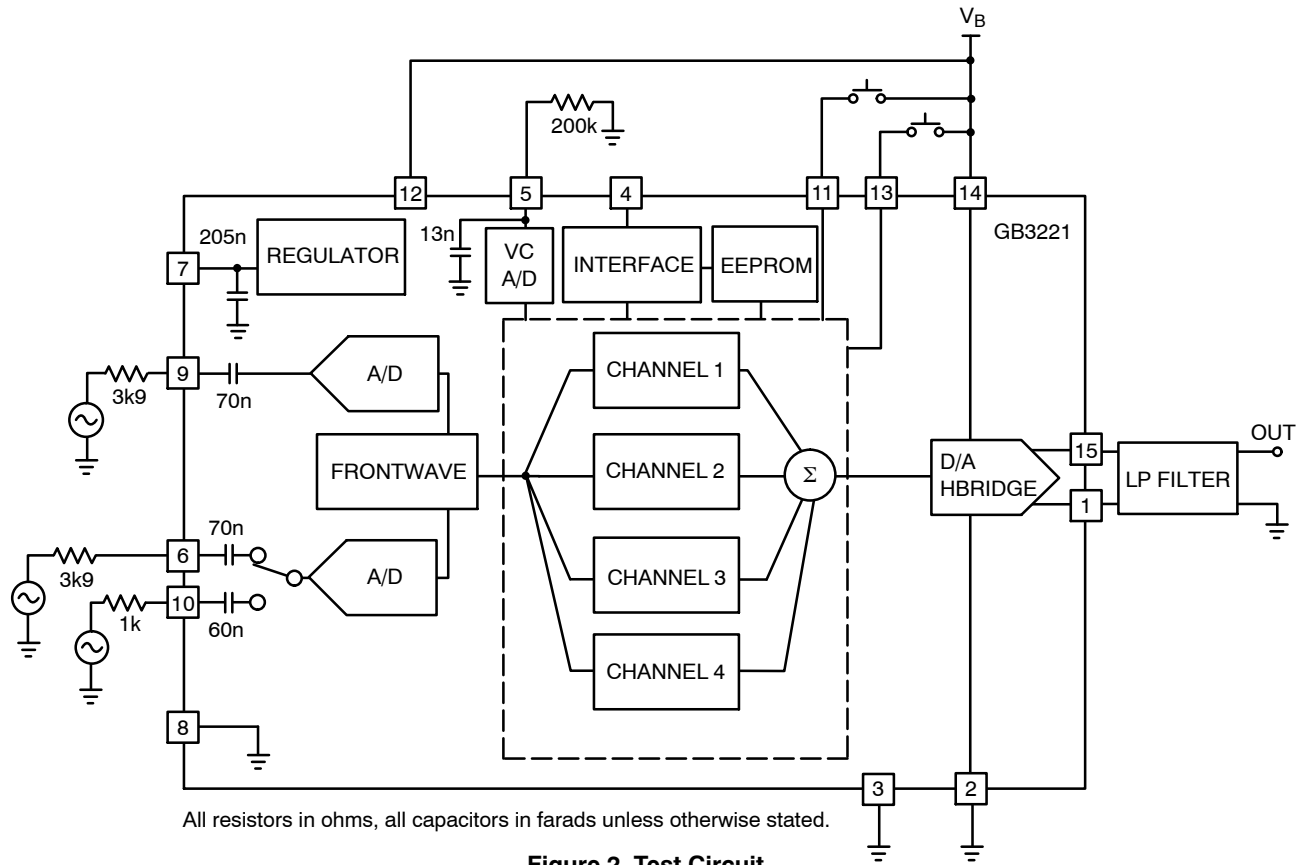

Figure 2. Test Circuit

# PARAGON GB3221

## TYPICAL APPLICATIONS (continued)

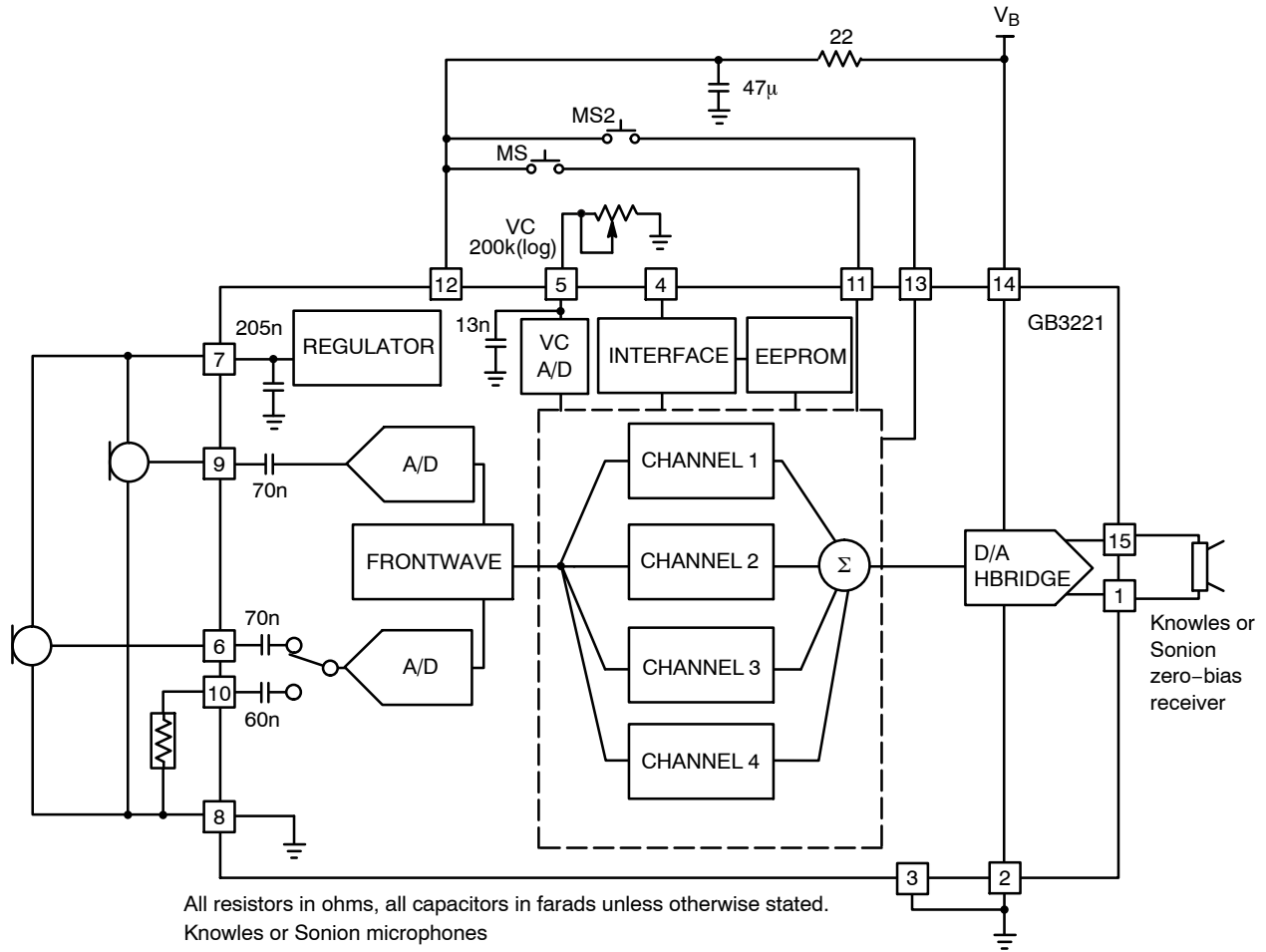

Figure 3. Sample Application Circuit

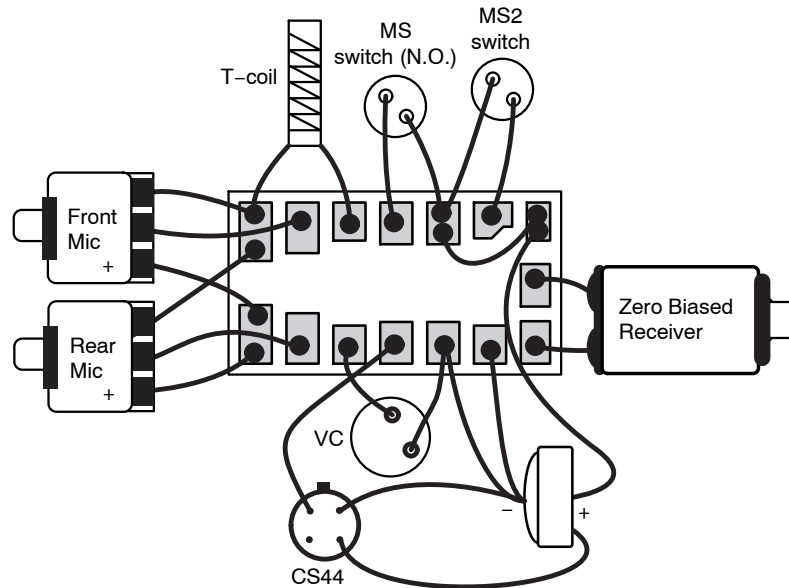

Figure 4. Assembly Diagram

# PARAGON GB3221

**Table 3. PAD POSITION AND DIMENSIONS**

Pad No.	Pad Position		Pad Dimensions	
	X	Y	Xdim (mil)	Ydim (mil)
1	0	0	20	29
2	-31	-1.5	22	26
3	-63	-0.25	22	28.5
4	-95	-0.25	22	28.5
5	-127	-1.5	22	26
6	-159	2.75	22	34.5
7	-191	5.5	22	40
8	-191	75.5	22	40
9	-159	78.25	22	34.5
10	-127	82.5	22	26
11	-95	81.25	22	28.5
12	-63	81.25	22	28.5
13	-30	85.5	26	24.5
14	2	82.5	16	26
15	0	39	20	29
Pad No.	X	Y	Xdim (mm)	Ydim (mm)
1	0	0	0.508	0.737
2	-0.787	-0.038	0.559	0.660
3	-1.600	-0.006	0.559	0.724
4	-2.413	-0.006	0.559	0.724
5	-3.226	-0.038	0.559	0.660
6	-4.039	0.070	0.559	0.876
7	-4.851	0.140	0.559	1.016
8	-4.851	1.918	0.559	1.016
9	-4.039	1.988	0.559	0.876
10	-3.226	2.0965	0.559	0.660
11	-2.413	2.0638	0.559	0.724
12	-1.600	2.0638	0.559	0.724
13	0.762	2.172	0.660	0.622
14	0.051	2.096	0.406	0.660
15	0	0.991	0.508	0.737

# PARAGON GB3221

## PACKAGE DIMENSIONS

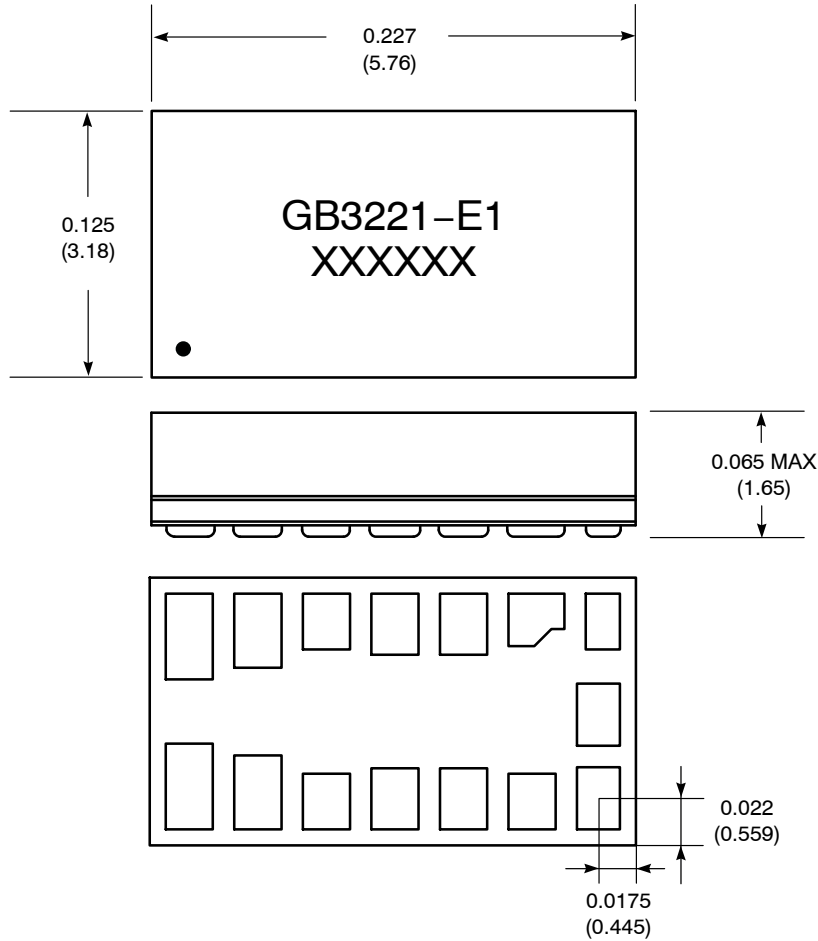

Dimension units are in inches.

Dimensions in parentheses are in millimeters, converted from inches and include minor rounding errors.

1.000 inches = 25.4 mm

Dimension tolerances:  $\pm 0.003$  ( $\pm 0.08$ ) unless otherwise stated.

● = location of Pin 1

Work order number: XXXXXX

RoHS compliant hybrid, MSL#4, 240°C peak reflow, SAC305.

This Hybrid is designed for either point-to-point manual soldering or for reflow according to ON Semiconductor's reflow process.

ARKonline, FRONTWAVE, and thinSTAX are registered trademarks of Semiconductor Components Industries, LLC.

HRX is a trademark of Semiconductor Components Industries, LLC.

ON Semiconductor and  are registered trademarks of Semiconductor Components Industries, LLC (SCILLC). SCILLC owns the rights to a number of patents, trademarks, copyrights, trade secrets, and other intellectual property. A listing of SCILLC's product/patent coverage may be accessed at [www.onsemi.com/site/pdf/Patent-Marking.pdf](http://www.onsemi.com/site/pdf/Patent-Marking.pdf). SCILLC reserves the right to make changes without further notice to any products herein. SCILLC makes no warranty, representation or guarantee regarding the suitability of its products for any particular purpose, nor does SCILLC assume any liability arising out of the application or use of any product or circuit, and specifically disclaims any and all liability, including without limitation special, consequential or incidental damages. "Typical" parameters which may be provided in SCILLC data sheets and/or specifications can and do vary in different applications and actual performance may vary over time. All operating parameters, including "Typicals" must be validated for each customer application by customer's technical experts. SCILLC does not convey any license under its patent rights nor the rights of others. SCILLC products are not designed, intended, or authorized for use as components in systems intended for surgical implant into the body, or other applications intended to support or sustain life, or for any other application in which the failure of the SCILLC product could create a situation where personal injury or death may occur. Should Buyer purchase or use SCILLC products for any such unintended or unauthorized application, Buyer shall indemnify and hold SCILLC and its officers, employees, subsidiaries, affiliates, and distributors harmless against all claims, costs, damages, and expenses, and reasonable attorney fees arising out of, directly or indirectly, any claim of personal injury or death associated with such unintended or unauthorized use, even if such claim alleges that SCILLC was negligent regarding the design or manufacture of the part. SCILLC is an Equal Opportunity/Affirmative Action Employer. This literature is subject to all applicable copyright laws and is not for resale in any manner.

### PUBLICATION ORDERING INFORMATION

#### LITERATURE FULFILLMENT:

Literature Distribution Center for ON Semiconductor  
P.O. Box 5163, Denver, Colorado 80217 USA

Phone: 303-675-2175 or 800-344-3860 Toll Free USA/Canada

Fax: 303-675-2176 or 800-344-3867 Toll Free USA/Canada

Email: [orderlit@onsemi.com](mailto:orderlit@onsemi.com)

N. American Technical Support: 800-282-9855 Toll Free  
USA/Canada

Europe, Middle East and Africa Technical Support:

Phone: 421 33 790 2910

Japan Customer Focus Center

Phone: 81-3-5817-1050

ON Semiconductor Website: [www.onsemi.com](http://www.onsemi.com)

Order Literature: <http://www.onsemi.com/orderlit>

For additional information, please contact your local  
Sales Representative